

Generation Overview

Pinnacle West Generation

- Existing generation
- Generation expansion
- Market position

Major Generators in the West

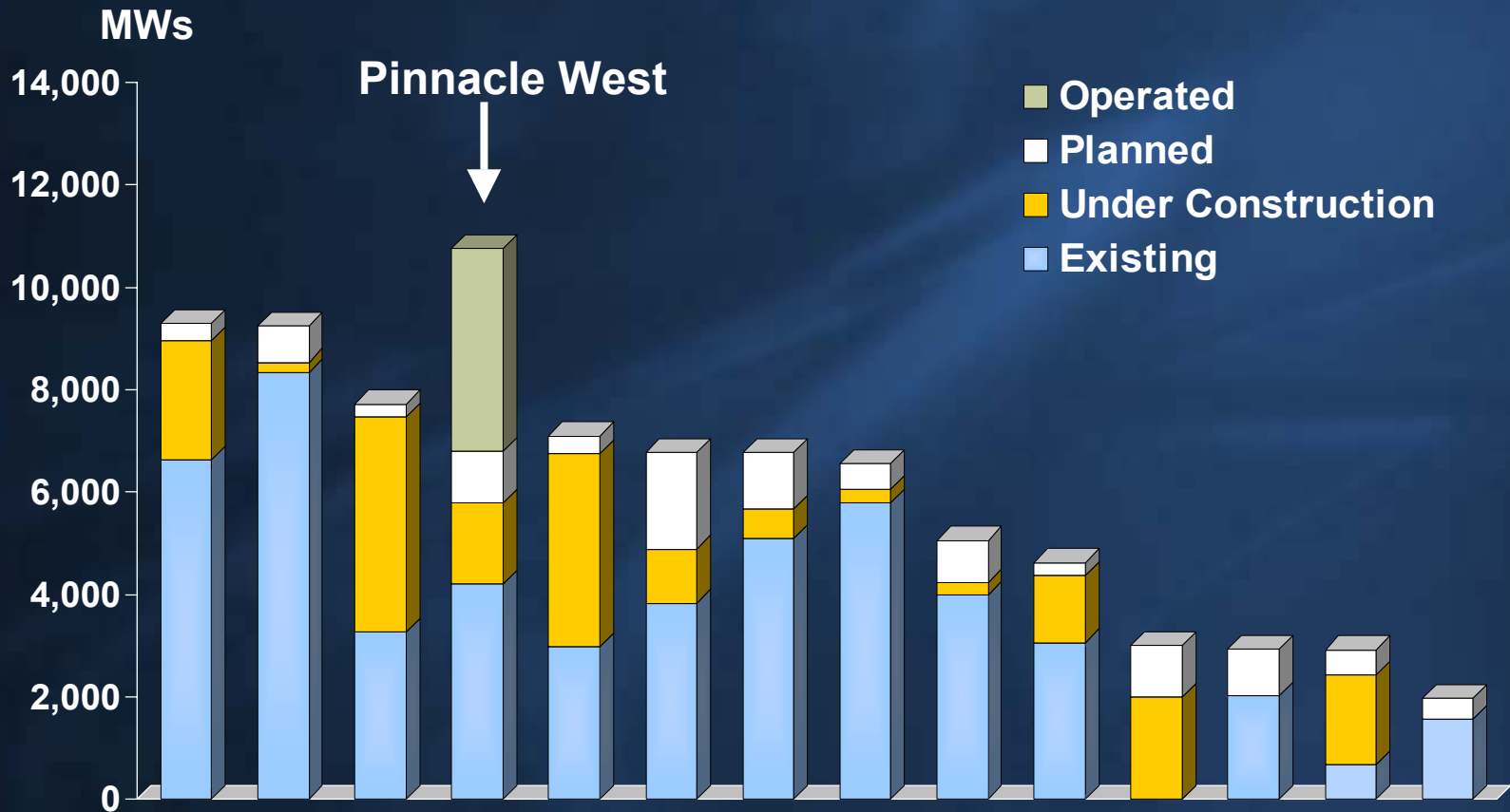

Competitive Baseload Production Cost

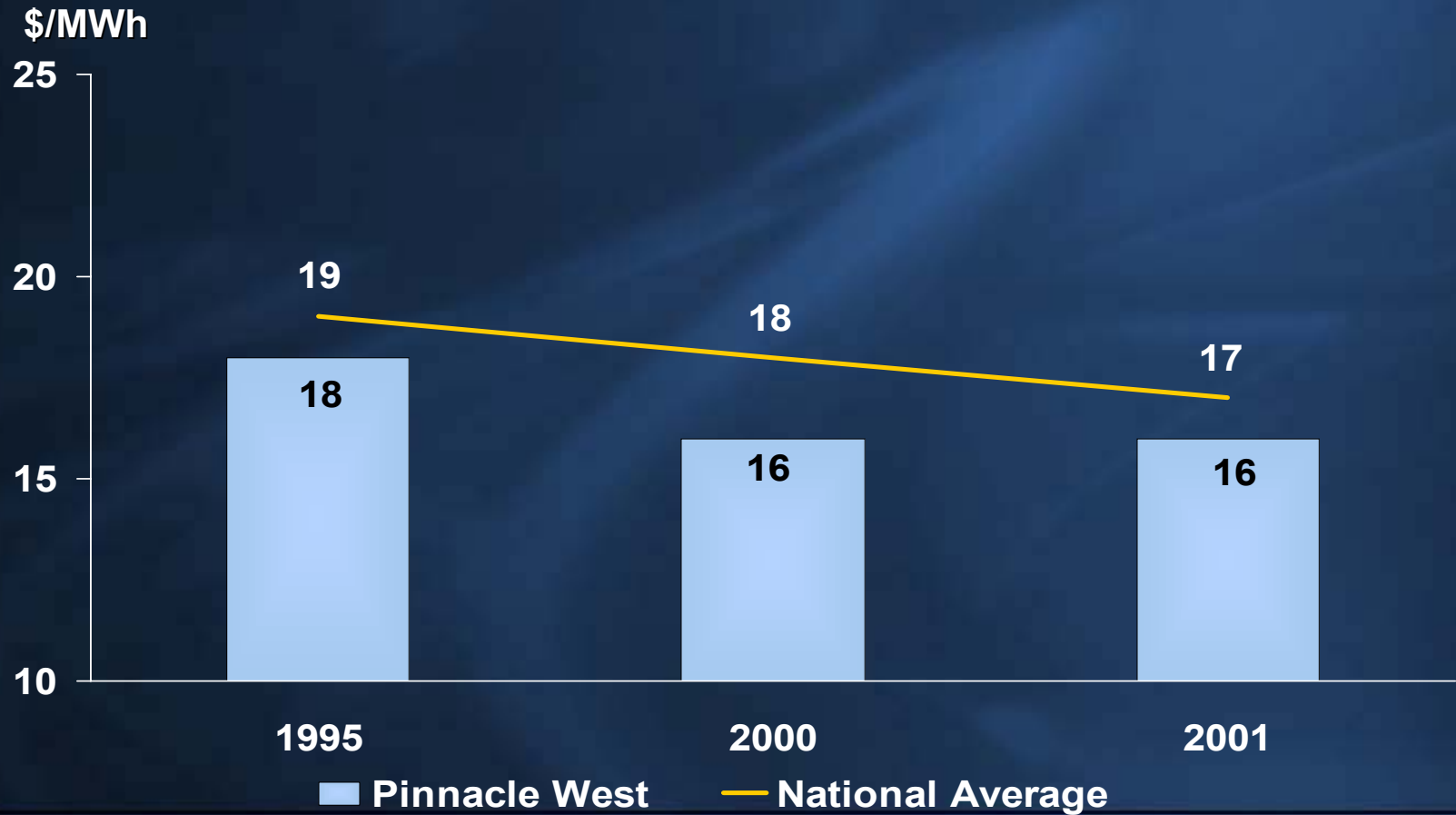

Top-Tier Power Plant Performance

Palo Verde

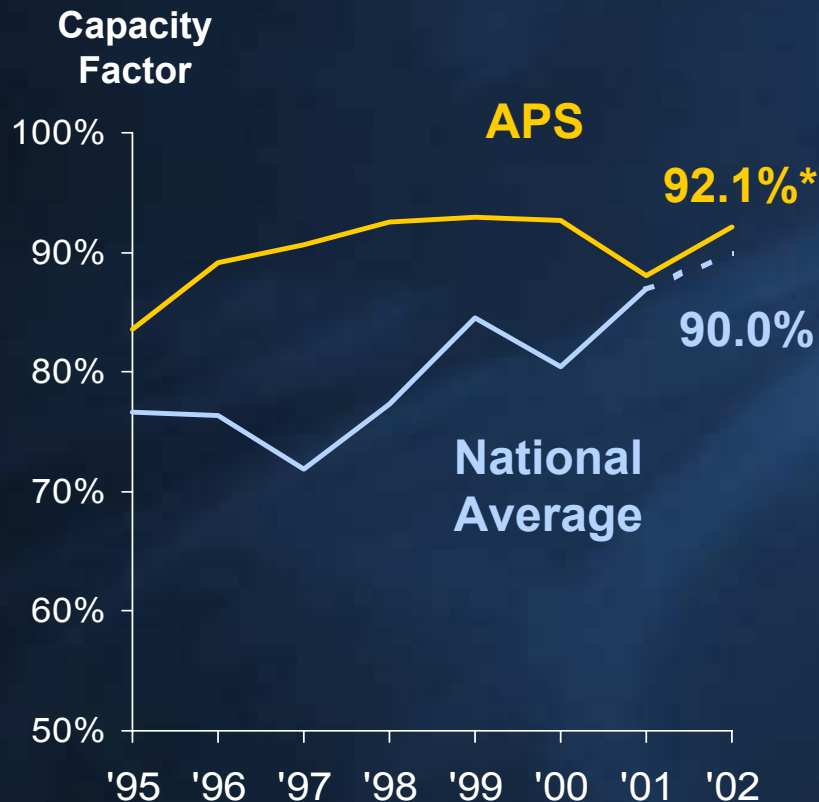

* Year-to-date April 15, 2002

Coal Plants

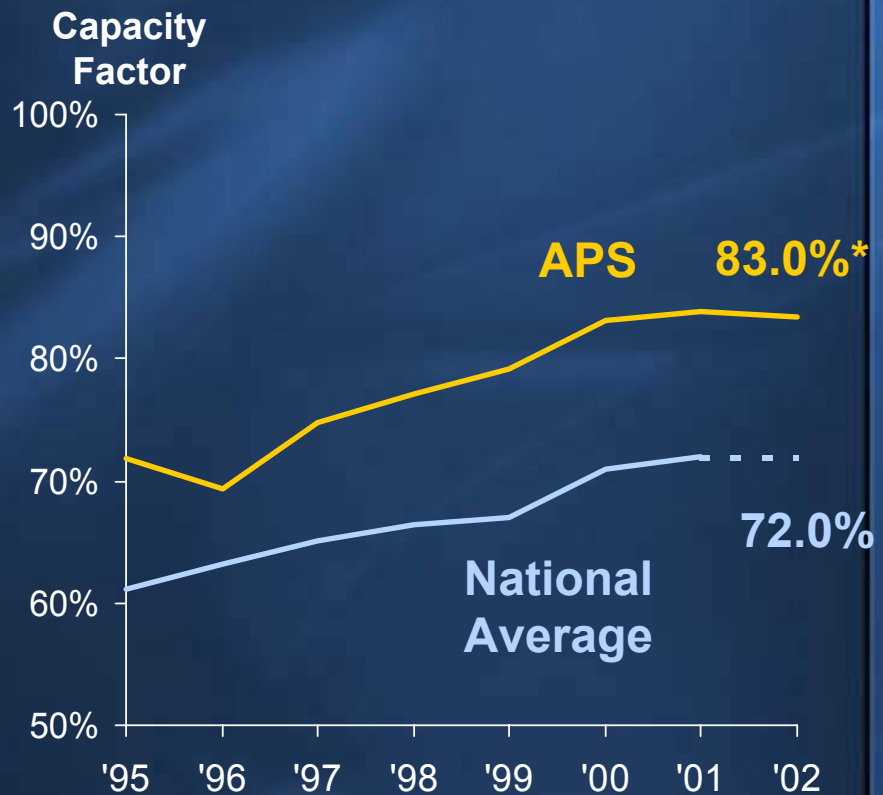

* Year-to-date April 15, 2002

Pinnacle West Generation

- **Coal plant performance**
 - Surpassed generation records in 2001
 - 2001 capacity factor of 84%
- **Gas units**
 - High availability
 - West Phoenix CC4: 99.8% availability
- **Nuclear performance**
 - Fourth consecutive INPO 1
 - Met the challenges of two simultaneous outages

Palo Verde Refueling Outages

- **Unit 2 - Spring 2002**
 - **Reactor vessel head inspection complete - no repairs required**
 - **Modifications made for steam generator replacement in Fall 2003**
- **Unit 1 - Fall 2002**
 - **Reactor vessel head inspection**
 - **Steam generator chemical cleaning**

Nuclear Reactor Vessel Head

6- 8 inches carbon steel

Control Element Drive Mechanism

3/8 inch stainless steel cladding

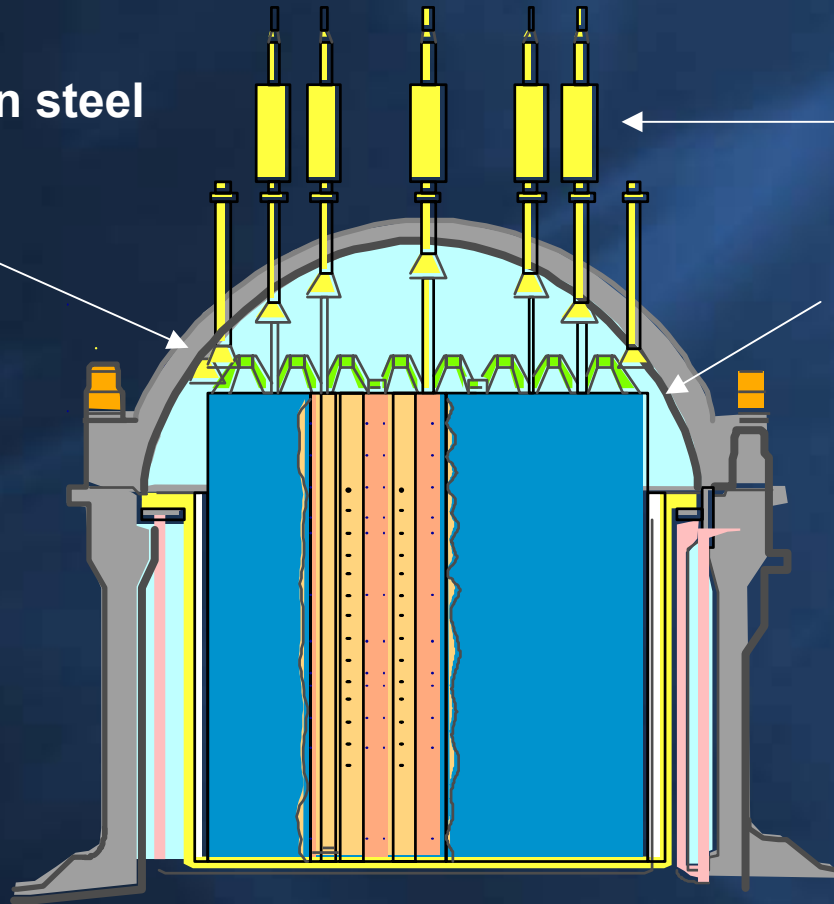

Steam Generator Replacement



Copper Eagle Natural Gas Storage

Drilling, testing, analysis

Negotiate bids for storage capacity

Prepare permits

**Targeted
Project
approval**

**First
Cavern
in
operation**

Jan

Feb

Mar

Apr

May

Jun

July

Aug

Sep

July

2002

2005

Pinnacle West

Generation Expansion Strategy

- **Disciplined**
- **Flexible to meet load growth**

Pinnacle West

Growing Generation Capability

| <u>Commercial Operation</u> | <u>New Facilities</u> | <u>MW's</u> |
|-----------------------------|-----------------------|-------------|
| 2001 | West Phoenix 4 | 120 |
| 2002 | Redhawk 1 & 2 | 1,060 |
| 2002 | Saguaro CT 3 | 80 |
| 2003 | West Phoenix 5 | 530 |
| 2004 | Silverhawk | 570 |
| 2006/2007 | Redhawk 3 and 4 | 1,060 |

Pinnacle West Generation Resources

Growing in Pace with Demand

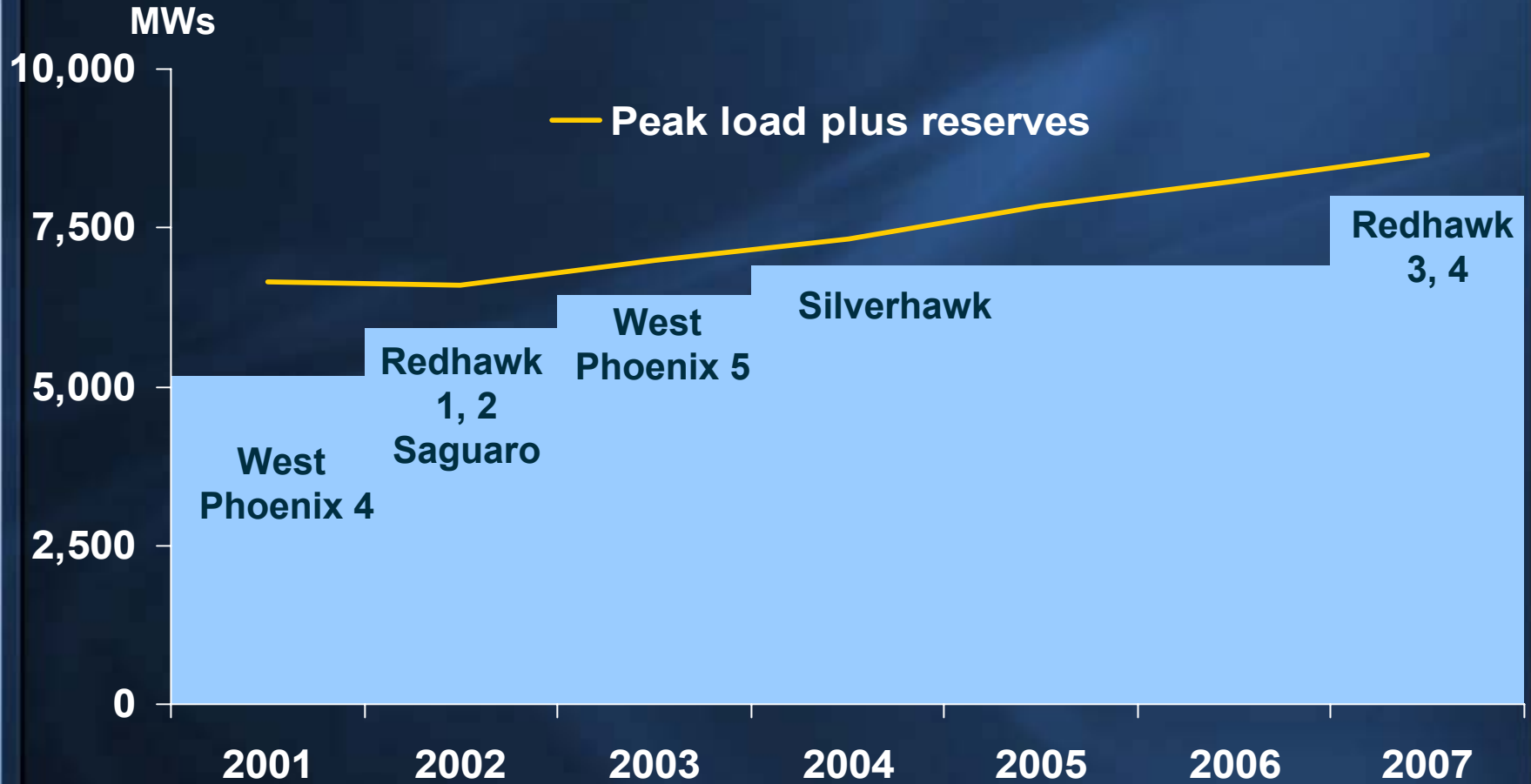

Southwest Electricity Supply & Demand

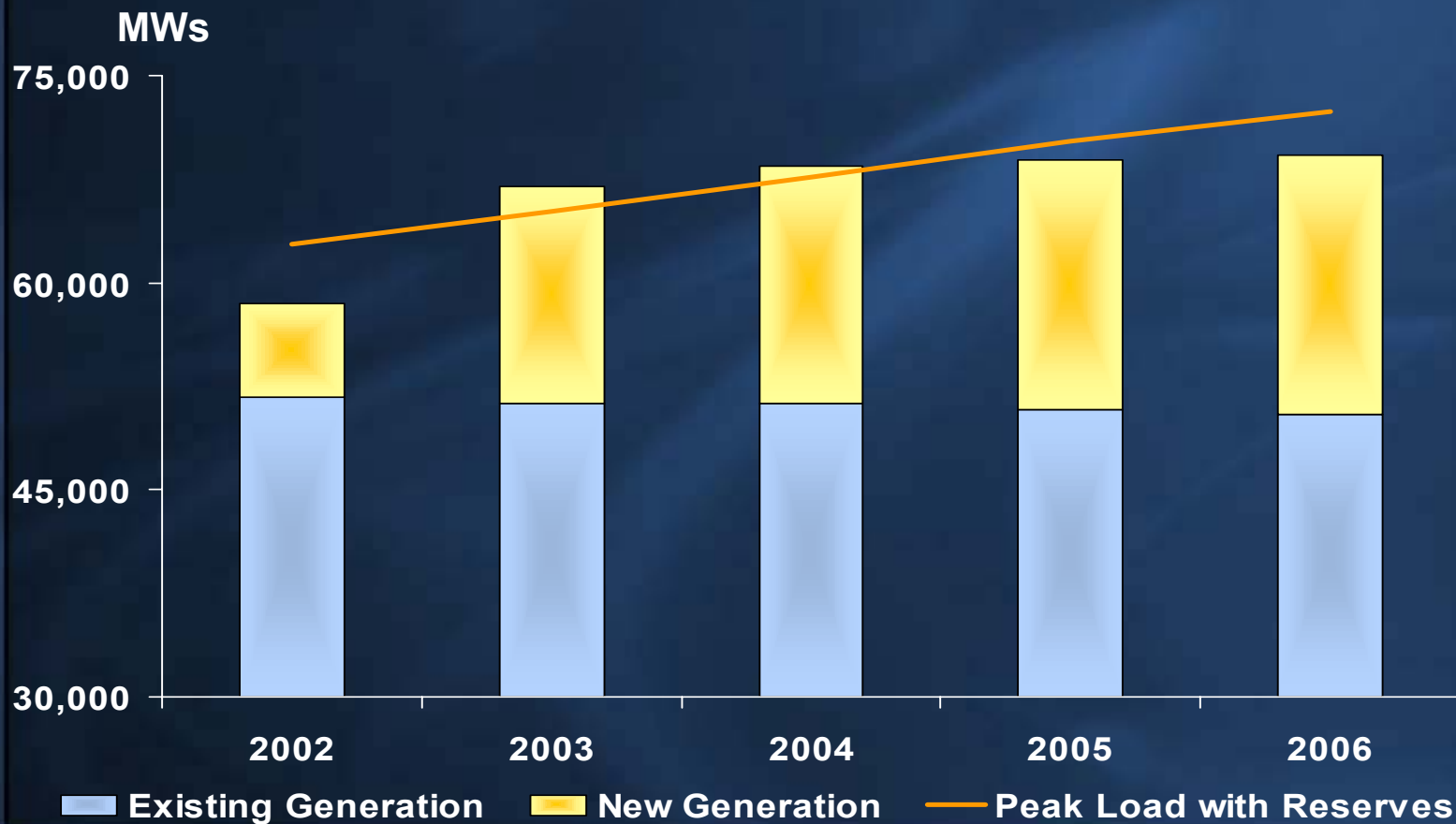

Pinnacle West Generation

Fuel Mix

2004

- Dependable, stable supply mix
- PNW will benefit from the market during low hydro or high gas years

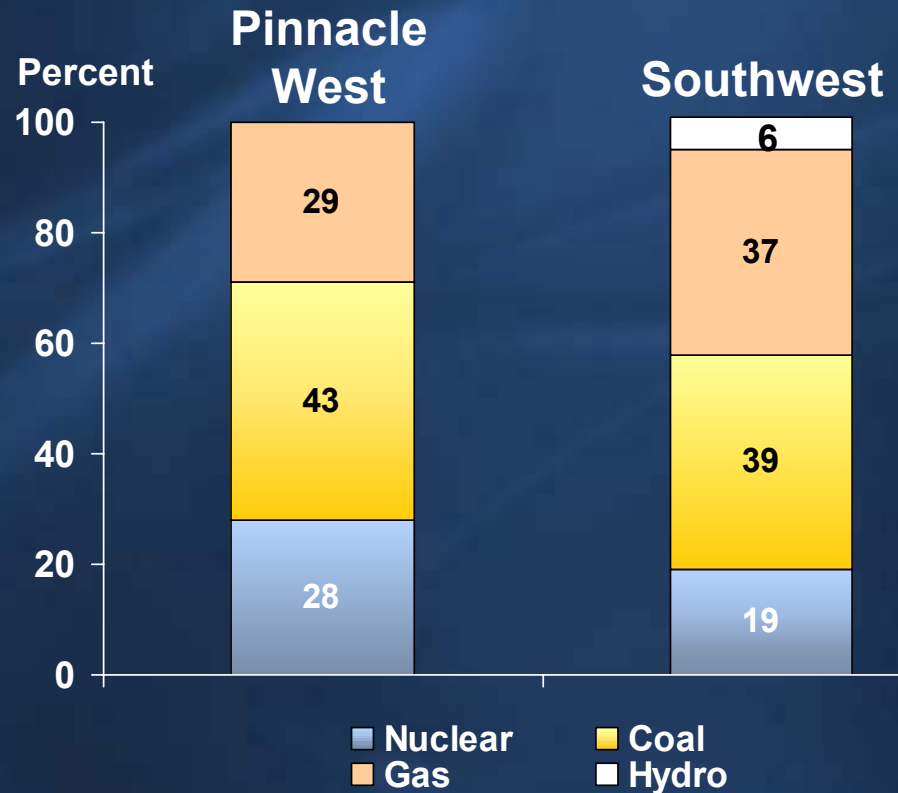

Pinnacle West Total Generation Cost

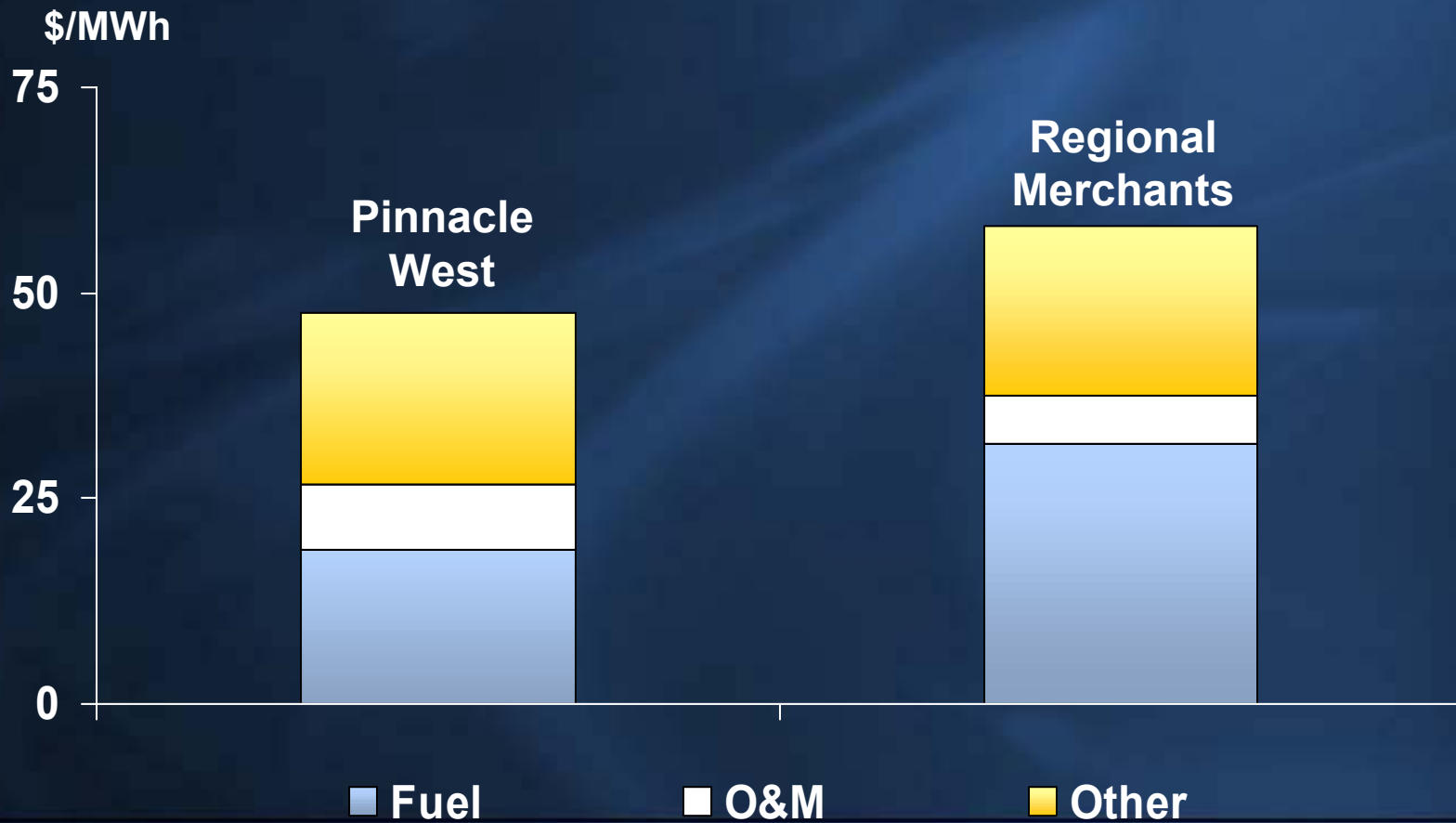

Pinnacle West

Generation Summary

- **Favorable fuel mix**
- **Competitive production cost**
- **Top nuclear and coal production**
- **High plant reliability**
- **Disciplined expansion plan**